

# WARRANTY

(Effective January 1, 2007)

HIX will automatically register the equipment on the date it was shipped to you or your distributor. If the equipment was not purchased directly from HIX, but through a distributor (either domestic or foreign), please keep a copy of their sales invoice showing the serial number and date it was sold/shipped to you with this warranty. In this case, we will use the distributor's invoice date as the beginning warranty date. **STAPLE A COPY OF YOUR RECEIPT TO THIS WARRANTY** and keep in a safe place to provide verification of your warranty should a problem occur. Thank you.

Please fill in the following information and attach a copy of your receipt for your records.

Date Purchased: \_\_\_\_\_ From: \_\_\_\_\_

Model #: \_\_\_\_\_ Serial #: \_\_\_\_\_

This warranty applies to equipment manufactured by the HIX Corporation (HIX), Pittsburg, Kansas, U.S.A. HIX warrants to the original purchaser, its Conveyor Dryers, Heat Transfer Presses, Mug Presses, Mug Glazer, Retensionable Screen Frames, Textile Printers, Spot Heaters, and Exposure Units against defects in workmanship and material, except for wear and tear for a period of "One Year" from the date of purchase. HIX warrants its Accessories, Reten Splines/Hardware/Tool Kit, and Shuttle for a period of 90 days from the date of purchase. DoughXpress and Thermatrol products are covered under separate warranty.

In the event of a defect, HIX, at its option, will repair, replace or substitute the defective item at no cost during this period subject to the limitations of insurance and shipping costs stated below.

In the case of heat transfer presses (except the Mug Press, Hobby Lite), HIX warrants the heat casting for the "Life" of the machine for the original purchaser. If a part becomes obsolete at the time for repair, and/or cannot be reasonably substituted for, HIX will credit, at half the then current list price or last recorded price, only that part toward a new machine or any product HIX offers. This credit offer shall be the sole responsibility of the HIX Corporation in the event of an obsolete part.

This warranty does not cover belts, pads, mug wraps, mug press liners, canvas, rubber blankets, bulbs, glass, PTFE or finish, rod ends, turn buckles on printers, or mug press or damages due to accident, misuse/abuse, alterations or damage due to neglect, shipping or lack of proper lubrication or maintenance. HIX shall not be responsible for repairs or alterations made by any person without the prior written authorization by HIX. This warranty is the sole and exclusive warranty of HIX and no person, agent, distributor, or dealer of HIX is authorized to change, amend or modify the terms set forth herein, in whole or in part.

In the case of a problem with the equipment identified herein, HIX Corporation should be contacted during regular business hours to discuss the problem and verify an existing warranty. HIX personnel will assist the customer to correct any problems which can be corrected through operation or maintenance instructions, simple mechanical adjustments, or replacement of parts. In the event the problem cannot be corrected by phone, and upon the issuance of a return authorization by HIX, the equipment shall be returned to HIX or an authorized service representative. All insurance and shipment/freight costs are solely the responsibility of the customer, and not that of HIX, and HIX shall not be responsible for improper handling or damage in transit. HIX offers a reconditioning service and a core exchange/credit policy on some models. HIX customer service personnel may be contacted for complete return authorization and reconditioning information.

This expressed warranty is given in lieu of any and all other warranties, whether expressed or implied, including but not limited to those of merchantability and fitness for a particular purpose, and constitutes the only warranty made by HIX Corporation.

In no event shall HIX's liability for breach of warranty extend beyond the obligation to repair or replace the nonconforming goods. HIX shall not be liable for any other damages, either incidental or consequential, or the action as brought in contract, negligence or otherwise.

This warranty gives you specific legal rights and you may also have other rights which vary from state to state.



Manufacturers of the Finest Quality Textile and Graphics Screen Printing and Heat Transfer Equipment

1201 E. 27th Terrace • Pittsburg, KS 66762 • U.S.A.

Web site: www.hixcorp.com • Phone: (800) 835-0606

E-Mail: customerservice@hixcorp.com • Fax: (866) 561-0894

E-Mail: sales@hixcorp.com • Fax: (866) 563-4600

# B-250 / B-250D Cap FH-3000D Combo/Flat/Cube Heat Transfer Machines

## OWNER'S MANUAL



B-250D



FH-3000D  
w/Flat Attachment

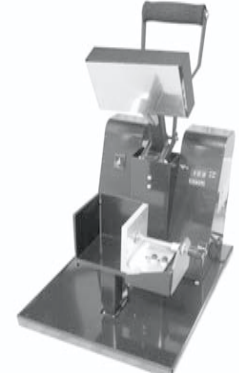

FH-3000D  
w/Cube Attachment



For Customer Service, Call 1-800-835-0606

ext. 209, ext. 211, ext. 220, ext.221 or

Visit [www.hixcorp.com](http://www.hixcorp.com)

## CONTENTS

Receiving & Installation .....	2
Temperature & Time Instructions .....	2-3
Pressure Adjustment .....	3
Transfer Application Instructions .....	4
Changing Combo Press Attachments .....	5
Maintenance .....	5
Troubleshooting .....	6-7
Analog Thermostat Bypass .....	8
Fuse Replacement .....	9
Toggle Adjustment .....	10
Microswitch Adjustment .....	10
Parts Identification .....	11-14
FAQ's .....	15
Warranty .....	16

**BEFORE warranty repair you MUST get Prior Authorization:  
Call 1-800-835-0606**

**NOTE: Manual includes B-250 (Analog)-  
B250D (Digital) and FH-3000D (Digital).**

## **INSTALLATION / OPERATION**

### **INSPECTION**

Inspect your machine for hidden shipping damage. Contact the delivery company immediately, should you find damage.

### **SHIPPING OR RETURNS**

**NOTE:** Save all of your shipping/packing materials.  
**DO NOT RISK COSTLY SHIPPING DAMAGE!  
SHIP ONLY IN ORIGINAL BOX.**

1. Fasten machine to plywood shipping base with bolts provided.
2. Tie or tape handle securely to base.
3. Place in original box, and put side liner and top liner in place. Fold in flaps and seal the box.  
(Additional bottom boards, box and liners may be obtained from your supplier for a nominal cost.)

### **UNPACKING/SETUP**

1. Remove and save bolts attaching machine to base board.
2. Carefully cut tape/wrap holding machine closed.
3. Affix self-adhesive rubber feet.
4. Plug the machine into the correct grounded electrical outlet.

**WARNING: When using an extension cord, use 12 or 14 ga.-3 conductor. Maximum length, 25' (7.62 m).**

## **OPERATION**

### **TEMPERATURE & TIME INSTRUCTIONS(ANALOG)**

1. The **B-250 Analog** temperature control knob is turned to the desired setting that is noted; from off to 400°F. When the set temperature has been reached, the heat indicating light will turn off.
2. Time; see separate instructions that are included with digital hand timer. Item#12718.



## **FAQ'S**

**Question: Can I transfer onto a 5 Panel Cap?** Answer: Yes – the front of the 5 Panel Cap has no seam running down the middle, therefore you can easily transfer onto the cap front.

**Tip:** Keep all transfers 3/8" away from seams.

**Question: Can I transfer onto a 6 Panel Cap?** Answer: Yes – but because of the seam running down center of front of cap you will need to separate your art transfer or flock design to avoid trying to transfer into the seam. Remember– separation must be 3/8" away from seam. (both sides of seam)

**Question: Are the lower platens interchangeable?** Answer: Yes there are three different sizes available – youth, golf and ball.

**Question: What is the PTFE Blanket used for?** Answer: It helps prevent movement of your transfer while lowering the heat head. It also helps prevent scorching of the nylon & poly fibers and sticking. If applying adhesive backed patches it keeps the adhesive from oozing from under the patch from getting on the heat head. And helps to keep the edges from curling up after the heat head is raised and while the adhesive is cooling.

**Question: How do you adjust the Pressure? Where is the Pressure Adjustment located?** Answer: A small "thumb" type adjustment control is located on the front of the machine. Turning the wheel left offers more pressure. Turning the dial right offers less pressure.

**Question: How much pressure do I need?** Answer: Time, Temperature and Pressure for transfers vary – depending on the transfer you are using. Please follow the directions provided by your heat transfer/heat transfer paper manufacture for specific instructions.

**Tip:** Always experiment when using a new supply of caps or transfers to get best results.

**Question: How do I load a hat in my press?** Answer: Place the back of the cap under the spring tensioned hold down, pull inside liner (also known as the linger or sweat band) out against the bill of the hat, slide the cap over lower platen and pull to snug on the platen.

**Tip:** Make sure the bill of the cap and cord is clear of the platens.

**Question; Can you do sleeves, pockets using the Cap Press? What else?** Answer: Although, the Cap press is designed primarily for caps it can do sleeves, pockets, as well as, visors, socks and under garments. The FH-3000D, which is a 3-3/4" x 6" flat press, perfect for the other small items beyond hats.

## PARTS IDENTIFICATION

ITEM	QTY	PART NUMBER	DESCRIPTION
6	1	31823	MICROSWTICH ASSY
9	1	57118	FUSE HOLDER
10	1	72223	TERMINAL BLOCK
13	1	23057	RELAY 10A SS 3-32 VDC INPUT
45	1	72074	FUSE MDA-5 AMP
52	2	59765	CLAMP CABLE .313
63	1	2502213	BLANKET HOLDER
64	20	16774	WASHER .281X.625X.063 ZPS
65	1	34711	CONTROL TEMP PI BOARD
66	1	34681	CONTROL TEMP CVC PDB BOARD
67	1	34703	CONTROL TEMP CVC CABLE
68	4	36695	SPACER .171X.375X.188 NYLON

Parts List

**WARNING:** For continued protection against risk of fire, replace with the following fuses only:  
120 Volt Units - Buss MDA-5; 220 Volt Units - Buss MDA-3.

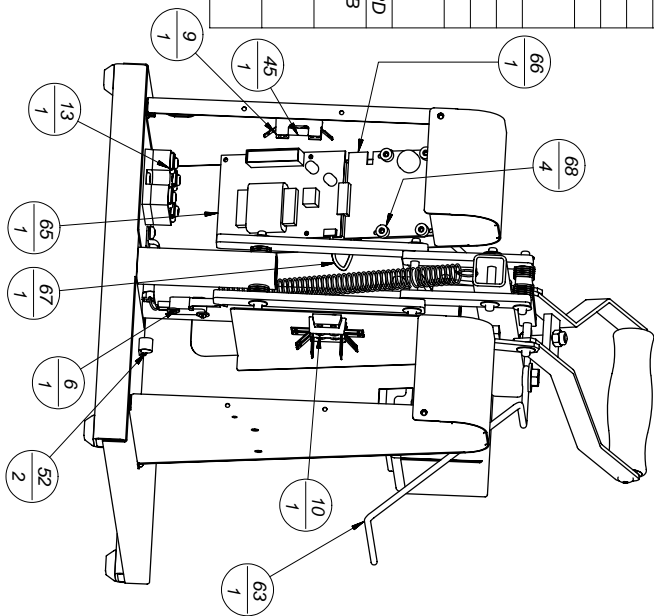

## OPERATION

### TEMPERATURE & TIME INSTRUCTIONS(DIGITAL)

The **B-250D** and **FH-3000D** use the following digital time and temperature control instructions.

1. Turn on the machine by pushing the on/off switch.
2. To change or set the temperature, press the menu button on the digital control. The light next to "TEMP" will light. Press the up ▲, or down ▼, button to your desired setting.
3. To change or set the time, press the menu button on the digital control. The light next to "TIME" will light. Press the up ▲, or down ▼, button to your desired setting.
4. When you have your desired settings **press the menu button a third time to lock in your settings** otherwise the previous settings will still be used.

Wait for the machine to reach your preset temperature by monitoring the display temperature until it matches the set temperature.



### PRESSURE - B-250 (DIGITAL) AND (ANALOG)

1. There is a pressure control knob located on the front stem, holding the lower platen. Set so that the heat head will lock down firmly, with your substrate in place.
2. Pressure is reduced by turning knob (with machine open) **counter-clockwise** and increased by turning it **clockwise**.

**NOTE:** Adjustments may be required from one item to another and will vary to achieve the desired result.

**CAUTION:** Excessive pressure can cause structural damage, voiding the machine warranty!

# OPERATION

## TRANSFER APPLICATION INSTRUCTIONS

1. Set the temperature, time, and pressure to the desired settings as instructed on pages 2-3.
2. Remove cardboard (if any) and fold out the sweatband.
3. Slip rear of cap under the spring-loaded cap holder.
4. Pull the bill and cap up and over the lower platen.



spring-loaded cap holder

5. Position cap and sweat band so that it just clears the upper platen when the machine is closed.
6. Align lettering or design.
7. Pull handle until the toggle bolt contacts and locks down the main arm. The timer begins counting when the handle is locked down.

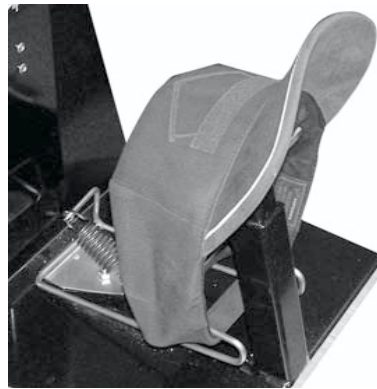

8. At the completion of the cycle (indicated by the timer beeping), raise the handle until the upper heat platen releases, peel transfer. The timer will automatically reset for the next product.

**NOTE:** When applying die cut, cold-peel, or sublimation transfers, the optional transfer hold-down should momentarily (3-5 seconds) remain in contact with the transfer after the heat platen has been released. You can also use high temperature tape to hold these types of transfers to your substrate. This will prevent the transfer paper from curling up on the ends and shifting the image. For hot-split transfers, peel the transfer immediately after lifting handle. When printing letters, the handle can be raised to its fully-open position at the end of the time cycle.

# PARTS IDENTIFICATION

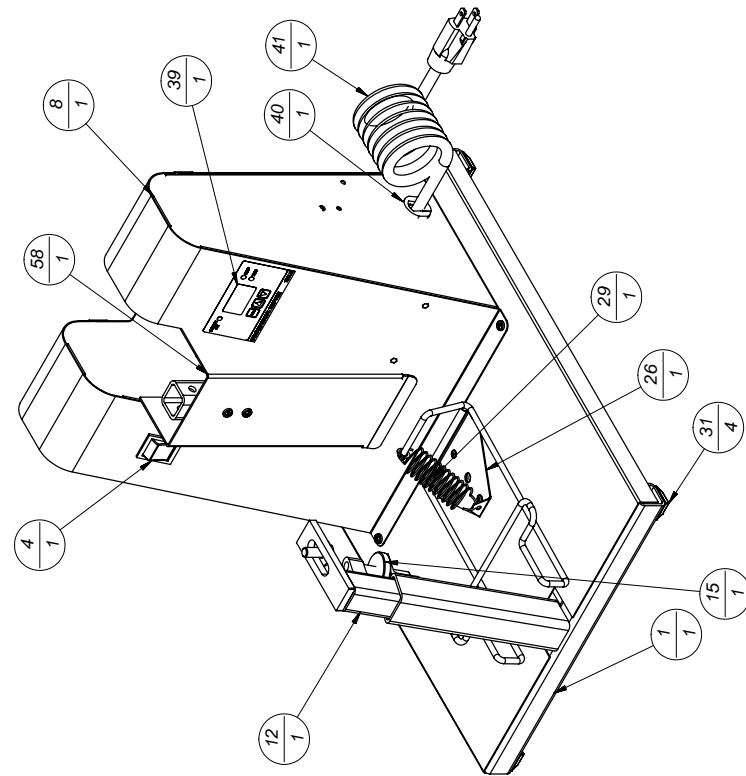

Parts List		
ITEM	QTY	PART NUMB DESCRIPTION
1	1	2500001 FRAME WELDMENT
4	1	32581 SWITCH ROCKER 120v
8	1	6001000 ASSY. 400 ENCLOSURE
12	1	2500005 PLATEN FRAME WELDMENT
15	1	2505004 ADJUSTMENT KNOB
26	1	2507012 250 CAP BRACKET PLATE
27	1	25542 B-250 BRACKET ROD
29	1	81901 SPRING JONES No 91
31	4	28010 FOOT RUBBER
33	1	64808 SPRING HIX #H-612 PLATED
39	1	62944 DECAL TEMP-TIMER
40	1	13250 CORD GRIP
41	1	60590 CORDSET
58	1	2502110 CENTER COVER

**For customer service, visit [www.hixcorp.com](http://www.hixcorp.com) or call 620-231-8568. Instructions and parts ordering are available on-line.**

# PARTS IDENTIFICATION

ITEM	QTY	PART NUMBER	DESCRIPTION
1	1	2500001	FRAME WELDMENT
2	1	2500002	MAIN ARM
3	1	2500003	HANDLE
13	1	23057	RELAY 10A SS 3-32 VDC INPUT
15	1	2505004	ADJUSTMENT KNOB
16	2	2502106	UPPER LINK
17	2	2502109	MIDDLE LINK
18	1	10686	BOLT 1/4-20 x 1-1/4 ZP
19	2	2505006	LINKAGE PIN LONG
20	2	2505005	LINKAGE PIN MEDIUM
21	2	2505007	LINKAGE PIN SHORT
22	12	71654	PUSH NUT .25 SHAF
23	1	14154	NUT 1/4-20 NYLOCK
24	1	26840	HANDLE GRIP FOAM
32	1	2503201	LOWER CASTING, GOLF
33	1	64808	SPRING HIX #H-612 PLATED
34	2	17301	GROMMET .563 IDx.750 GRV
35	2	16683	WASHER 5/16 USS ZP
36	1	10793	BOLT 5/16-18x1-3/4
43	5	81224	NUT HEX 4-40 ZP
46	1	14842	PAD CUT 3in
49	2	50181	SCREW HX WH THR CUT 25-20x.50
56	1	2502102	HANDLE LINK
63	1	2502213	BLANKET HOLDER

Parts List

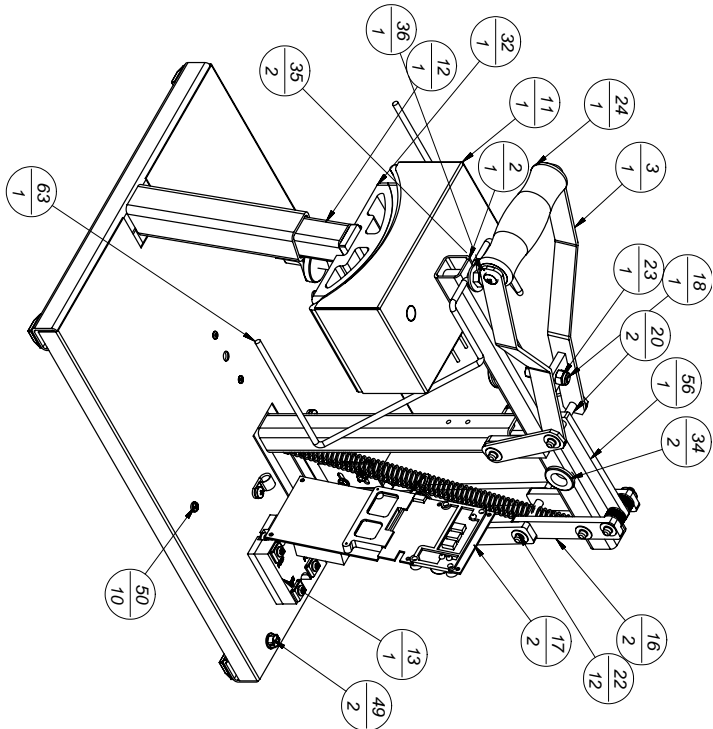

# OPERATION

## FH-3000D/ CUBE COMBO PRESS ATTACHMENTS

1. To switch the different attachments, just lift the attachment off, replace with other attachment. Adjust screw to change height.

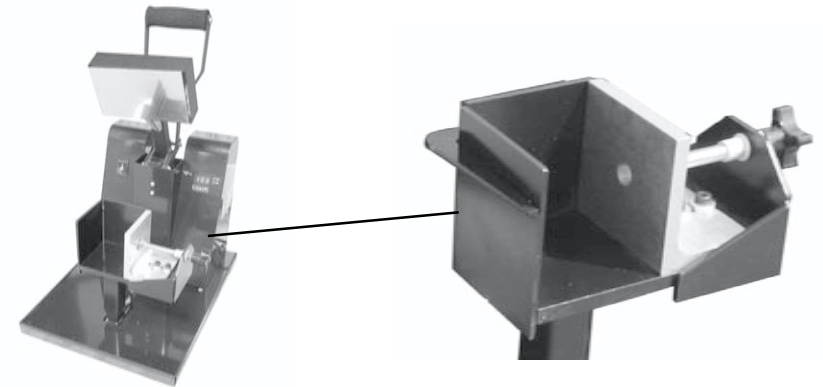
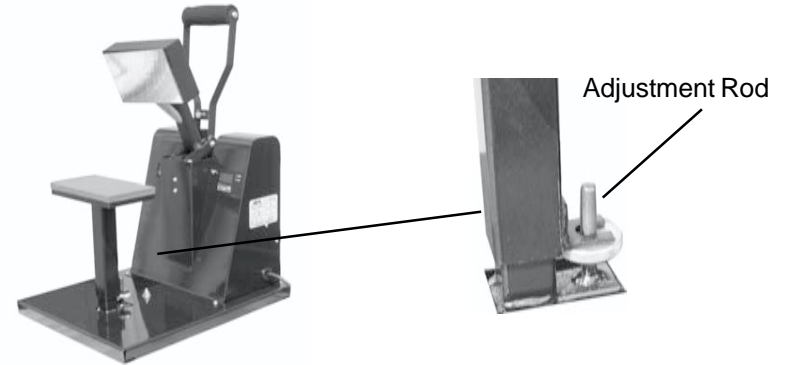

2. Load paper cube tight against the back and non moving side. Tighten adjustment knob.

**NOTE:** For **flat attachment**, simply align article on pad and adjust the pressure (at back, bottom of machine). For **cube attachment**, put product in and adjust for width and pressure.

# MAINTENANCE

1. Monthly, place drop of light oil (sewing machine oil or 3:1 oil) on all moving parts.

# TROUBLESHOOTING (DIGITAL MODELS)

**WARNING: Before making repairs, turn temperature control knob to "OFF" and unplug machine!**

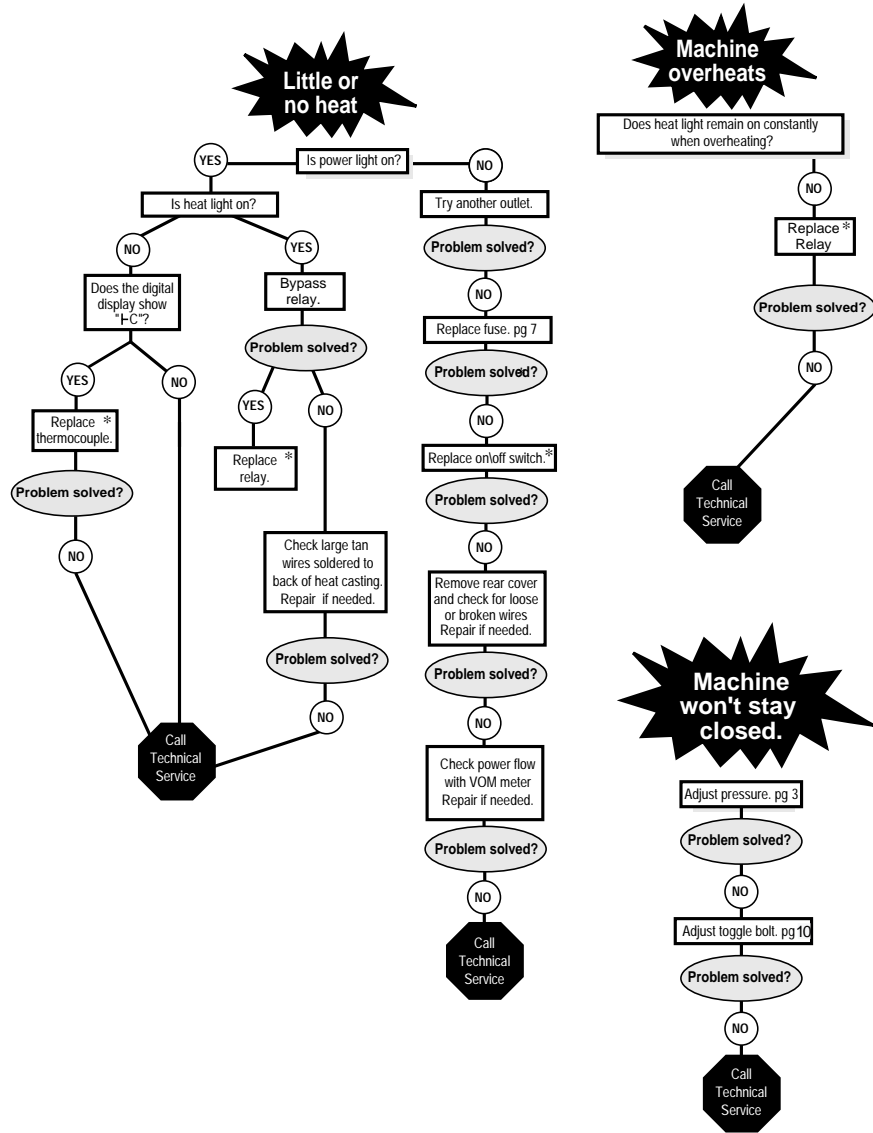

# PARTS IDENTIFICATION ANALOG ONLY

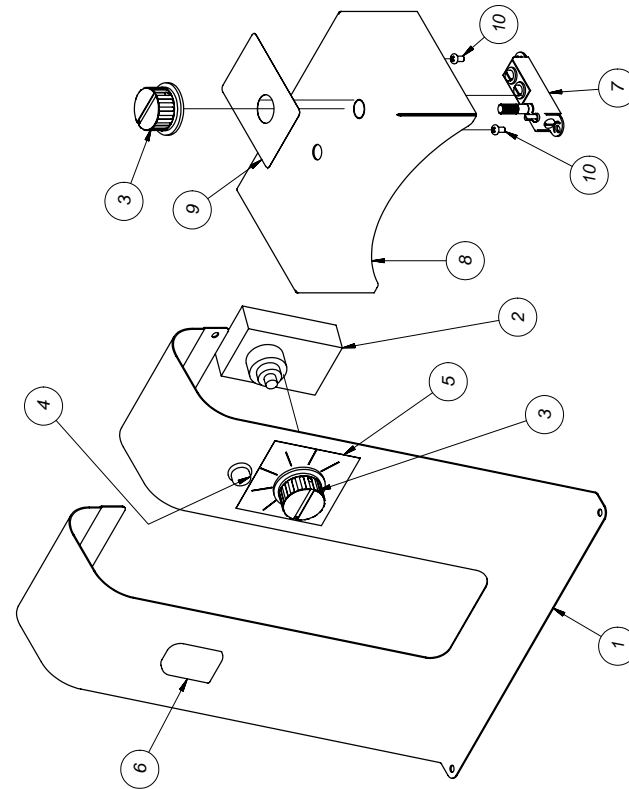

ITEM QTY		PART NUMBER	DESCRIPTION
1	1	6001007	FRONT SHEET - ND
2	1	16772	TIMER
3	2	94854	KNOB ( THERMOSTAT)
4	1	14233	LAMP ID RED 120V
5	1	16764	TIMER DECAL
6	1	35394	ROCKER SWITCH HOLE PLUG
7	1	16436	THERMOSTAT
8	1	2508003	HEATSHIELD
9	1	35157	DECAL TEMP 400 DEG
10	2	15438	SCREW TAP PH PHP 6x1/4 ZP

Analog Parts List

\*Customer Service Tech Sheets are available for this step. Visit [www.hixcorp.com](http://www.hixcorp.com) to print or call 620-231-8568 and we will send you one. Parts ordering is available on-line.

# REPAIRS

## TOGGLE ADJUSTMENT

**NOTE:** If machine is hard to open, follow step 1. If machine will not stay locked down, follow step 2.

1. Loosen the toggle bolt lock nut. Turn toggle bolt in 1/4 increments **clockwise** as viewed from top. Lock handle down. Repeat until machine operates comfortably and locks down securely. Tighten toggle lock nut and check operation. If turned too far, machine will not stay locked when closed.
2. If toggle bolt does not contact main arm and excessive pressure is required on handle, reduce pressure by turning pressure knob **counterclockwise**. Repeat. (See page 3, "Operations"). If contact is made but handle won't lock down, turn toggle bolt 1/4 turn (**counterclockwise as viewed from the top**). Repeat until handle locks down comfortably. Tighten toggle lock nut and check for proper operation.

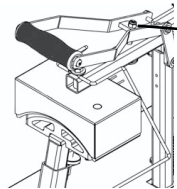

Toggle Bolt Lock Nut

## MICRO SWITCH ADJUSTMENT (see page 14, item #6)

*If countdown timer will not activate.*

**WARNING:** Before making repairs, turn temperature control knob to "OFF" and unplug machine!

1. Remove rear cover.
2. Using a screwdriver and a small wrench loosen micro switch mounting screws
3. Adjust switch so it "clicks" only when machine is locked down.
4. Tighten mounting screws, replace rear cover and check operation.

# TROUBLESHOOTING (ANALOG MODELS)

**WARNING:** Before making repairs, turn temperature control knob to "OFF" and unplug machine!

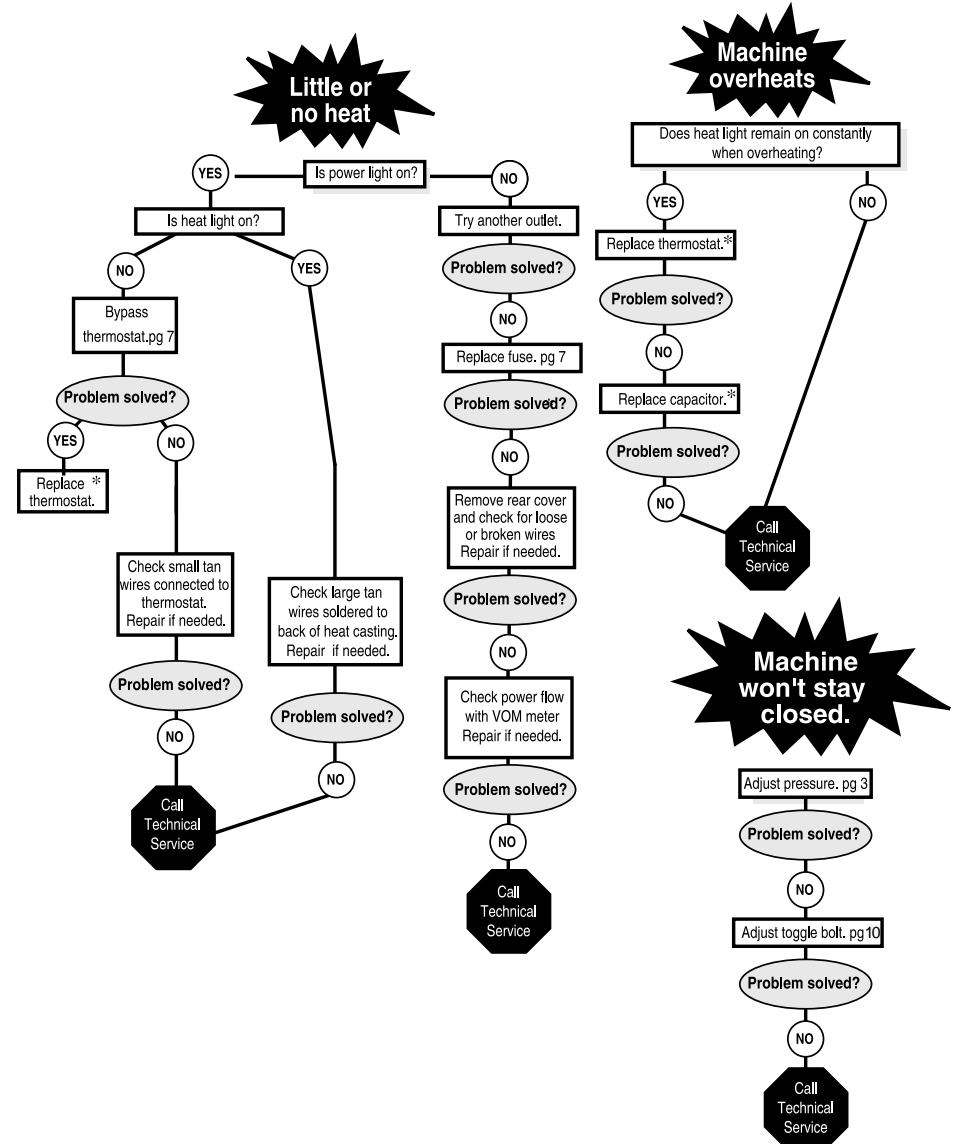

\*Customer Service Tech Sheets are available for this step. Visit [www.hixcorp.com](http://www.hixcorp.com) to print or call 620-231-8568 and we will send you one. Parts ordering is available on-line.

## REPAIRS

### THERMOSTAT BYPASS (B-250 ANALOG ONLY)

If your machine is not heating (temperature light does not come on).

**WARNING: Before making repairs, turn temperature control knob to “OFF” and unplug machine!**

1. Loosen recessed set screw in the thermostat knob and remove knob by pulling knob upward. **Fig. 3, Pg. 9**
2. Remove casting retaining bolt (**Fig. 1, Below**) to drop the heat head down from the main arm. Remove heat shield cover to gain access to the thermostat.
3. Attach both “thermostat wires” on the “**rear terminal**”. **Fig. 3, Pg. 9**
4. Plug machine in and turn temperature control to desired temperature.

If heat light comes on, and the machine starts heating, replace thermostat.

**NOTE:** If you feel your temp calibration is off contact customer service.

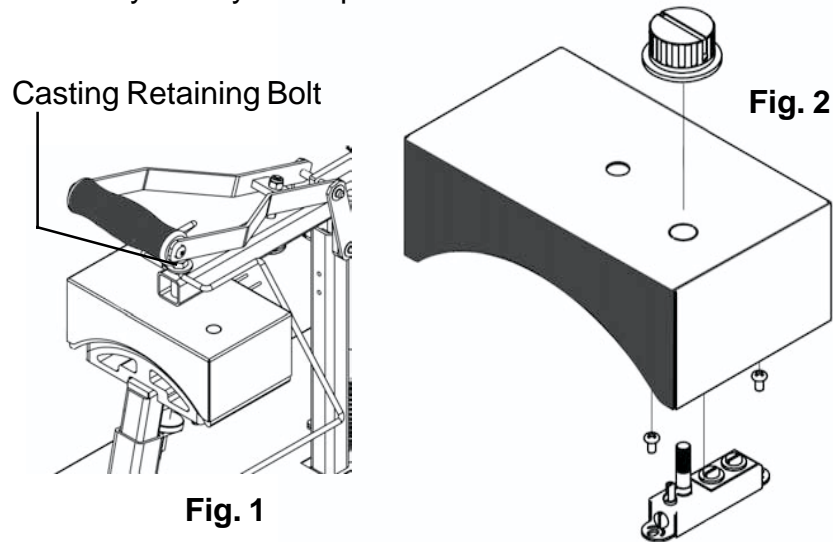

## REPAIRS

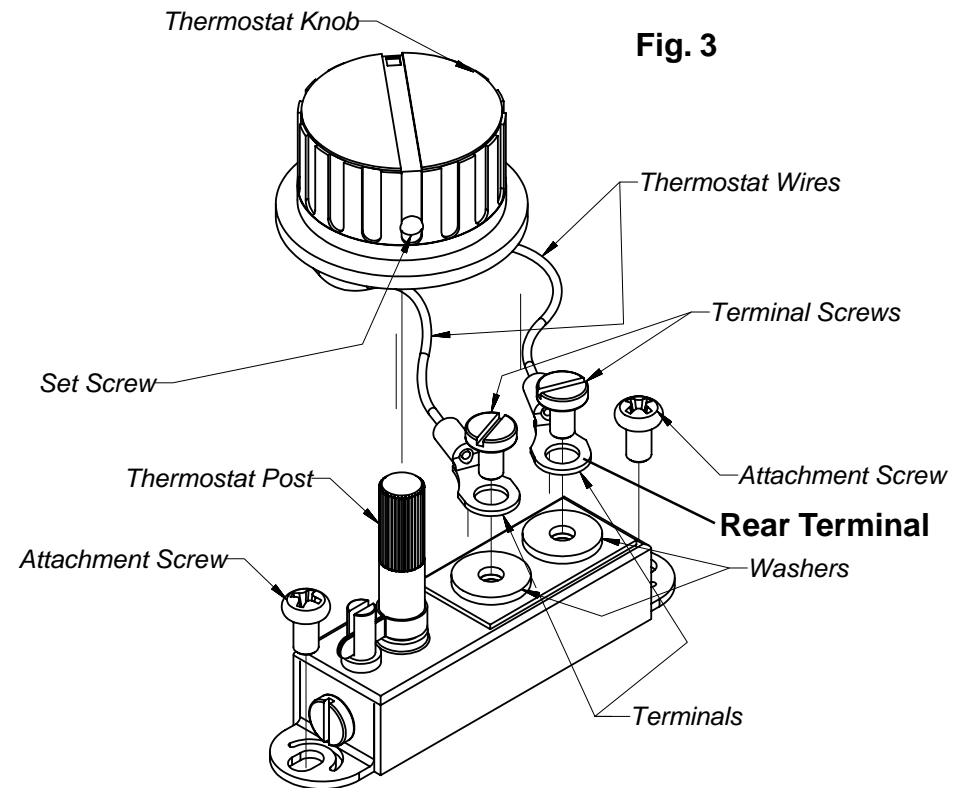

### FUSE REPLACEMENT (DIGITAL) AND (ANALOG)

**WARNING: Before making repairs, turn temperature control knob to “OFF” and unplug machine!**

1. Remove back cover of the machine and locate internal fuse holder on inside of the machine. (See page 14, item #9)
2. Remove blown fuse. Replace with the proper fuse.  
(120V) ..... MDA-5 ONLY  
(220V).. .... MDA-3 ONLY
3. Replace back cover of machine.