

WARRANTY

(Effective September 1, 2010)

HIX will automatically register the equipment on the date it was shipped to you or your distributor. If the equipment was not purchased directly from HIX, but through a distributor (either domestic or foreign), please keep a copy of their sales invoice showing the serial number and date it was sold/shipped to you with this warranty. In this case, we will use the distributor's invoice date as the beginning warranty date. **STAPLE A COPY OF YOUR RECEIPT TO THIS WARRANTY** and keep in a safe place to provide verification of your warranty should a problem occur. Thank you.

Please fill in the following information and attach a copy of your receipt for your records.

Date Purchased: _____ From: _____

Model #: _____ Serial #: _____

This warranty applies to equipment manufactured by the HIX Corporation (HIX), Pittsburg, Kansas, U.S.A. HIX warrants to the original purchaser, its Ovens and Dryers, Heat Transfer Presses, Mug Presses, Mug Glazer, Retensionable Screen Frames, Textile Printers, Spot Heaters, and Exposure Units against defects in workmanship and material, except for wear and tear for a period of "One Year" from the date of purchase. HIX warrants its Accessories, Reten Splines/Hardware/Tool Kit, and Shuttle for a period of 90 days from the date of purchase. Thermatrol and doughXpress products are covered under separate warranty.

In the event of a defect, HIX, at its option, will repair, replace or substitute the defective item at no cost during this period subject to the limitations of insurance and shipping costs stated below.

In the case of heat transfer presses (except the Hobby Lite), HIX warrants the heat casting for the "Life" of the machine for the original purchaser. If a part becomes obsolete at the time for repair, and/or cannot be reasonably substituted for, HIX will credit, at half the then current list price or last recorded price, only that part toward a new machine or any product HIX offers. This credit offer shall be the sole responsibility of the HIX Corporation in the event of an obsolete part.

This warranty does not cover belts, pads, mug wraps, canvas, rubber blankets, bulbs, glass, rod ends, turn buckles on printers or damages due to accident, misuse/abuse, alterations or damage due to neglect, shipping or lack of proper lubrication or maintenance. HIX shall not be responsible for repairs or alterations made by any person without the prior written authorization by HIX. This warranty is the sole and exclusive warranty of HIX and no person, agent, distributor, or dealer of HIX is authorized to change, amend or modify the terms set forth herein, in whole or in part.

In the case of a problem with the equipment identified herein, HIX Corporation should be contacted during regular business hours to discuss the problem and verify an existing warranty. HIX personnel will assist the customer to correct any problems which can be corrected through operation or maintenance instructions, simple mechanical adjustments, or replacement of parts. In the event the problem cannot be corrected by phone, and upon the issuance of a return authorization by HIX, the equipment shall be returned to HIX or an authorized service representative. All insurance, packaging and shipment/freight costs are solely the responsibility of the customer, and not that of HIX, and HIX shall not be responsible for improper packaging, handling or damage in transit. Contact HIX customer service for complete return authorization information. Correct shipping boxes are available from HIX.

This expressed warranty is given in lieu of any and all other warranties, whether expressed or implied, including but not limited to those of merchantability and fitness for a particular purpose, and constitutes the only warranty made by HIX Corporation.

In no event shall HIX's liability for breach of warranty extend beyond the obligation to repair or replace the nonconforming goods. HIX shall not be liable for any other damages, either incidental or consequential, or the action as brought in contract, negligence or otherwise.

This warranty gives you specific legal rights and you may also have other rights which vary from state to state.



Manufacturers of the Finest Quality Textile and Graphics Screen Printing and Heat Transfer Equipment

1201 E. 27th Terrace • Pittsburg, KS 66762 • U.S.A.

Web site: www.hixcorp.com • Phone: (800) 835-0606 • Fax: 620-231-1598

E-Mail: customerservice@hixcorp.com • E-Mail: sales@hixcorp.com

R2R

Reel to Reel Care Label Heat Press

OWNER'S MANUAL



R2R shown

HIX CORPORATION
For Customer Service, Call 1-800-835-0606
or Visit www.hixcorp.com

CONTENTS

Receiving	2
Installation	3-6
Operation	7
Sensor Setting	7-9
Transfer Application	10
Trouble Shooting	11
Warranty	12

**BEFORE warranty repair you MUST get Prior Authorization:
Call 1-800-835-0606**

RECEIVING & INSTALLATION

SHIPPING OR RETURNS

NOTE: Save all of your shipping/packing materials.

DO NOT RISK COSTLY SHIPPING DAMAGE!

SHIP ONLY IN ORIGINAL BOX.

1. Place in original crate.
2. Fasten machine to shipping base with bolts provided.
3. Make sure crate top is securely fastened to base

UNPACKING

Remember to save all packing materials - including box, liner and board. You may need these for shipping your machine or if a repair is necessary in the future.

INSPECTION

Inspect your machine for hidden shipping damage. Contact the delivery company immediately, should you find damage.

INSTALLATION

NOTICE: These machines are heavy, utilize team lifting and lift with your legs when placing the machine.

1. Remove shipping straps and bolts.
2. Supply a clean (void of oils) and dry (void of water) air source of 70 P.S.I. (6.8-8.5 bar) to the 3/8" NPT air inlet located on the back of the machine. Requires 4 CFM.



NOTE: It is strongly recommended that an external air filter and water trap be installed at the machine's air inlet connection. Compressed air is dirty. It has 'stuff', primarily moisture, residues from oil and smoke and whatever else is in the air. Compressors or 'shop air' may have filtered air and/or an "AIR DRYER" after the compressor. IF your air is not filtered and dried, YOU MUST FILTER THE AIR and REMOVE THE WATER AND 'STUFF' FROM THE AIR, before putting it in most air operated machines, including our press. There are small valves and ports that can become blocked from moisture and residue in compressed air, causing your press to malfunction. An external air filter and water trap must be installed at the machine's air inlet connection, if your air is not filtered. Damage to the machine's internal air operated components can occur that will not be covered under warranty. Combination air filter/water traps are available at any major hardware store or may be purchased directly from HIX (part #71145).

TROUBLESHOOTING

Symptom	Cause	Solution
1. Machine does not index properly.	Press set to Manual Sensor not set properly	De-Press Manual/ Auto button First make sure label is aligned properly. Re-Teach sensor. See "Sensor Section" pg 8.
2. Labels do not transfer properly.	Not enough heat, time or pressure.	Please refer to transfer specifications while most transfer target times range from 1-2 seconds. Pressure and Temperature settings may vary depending on fabric limitations.
3. Upper Platen does not move.	No air pressure.	Check that air connection is secure. Check that air supply has not been interrupted.
4. Unit does not come on	E-Stop button is on. Breaker Tripped Blown Fuse	Turn E-Stop clockwise and press Power button. Locate main breaker panel and flip tripped breaker to on position. See Diagram on page 12 for location of fuse.

TRANSFER APPLICATION

When you fail to make a successful transfer you can wonder, “Is it the machine’s fault, or the transfer, wrong settings or what”?

FIRST, THE BASICS:

1. Be sure to set the heat transfer machine to the transfer manufacturer’s recommended Temperature, Time and Pressure settings. If you don’t have these specifications, contact your transfer supplier for this information and any other special application instructions as many of the new “High Tech” transfers require significantly different settings and/or application techniques than those from years past.
2. When you start up your press for the first time each day, preheat the pad for a minute. If the press has sat for 3-5 minutes without use, be sure to “preheat” the pad for 10-15 seconds before loading the shirt or making the first transfer.
3. Be sure the T-shirt fabric is void of any moisture which can reduce the chance of a successful transfer.
4. With all of the above recommendations, try making a transfer.
5. If successful, great! You are on your way to making some serious money with your transfer machine!
6. If you have an area that isn’t transferring completely or as you would like it to, follow these steps to determine the problem.
 - Try increasing the pressure on the machine by 10-20%
 - Recheck your temperature required and the press readout. You may want to increase the temperature 10 degrees.
 - Try increasing the application time by 2-4 seconds
 - If after trying these things there is still a “specific” area (say over in one corner of the transfer) that isn’t coming out as you would like it to, then try the same type transfer on a scrap shirt but rotate the transfer 180 degrees (changing the failure location) If after doing this the problem area is in the same physical location on the machine, then you probably have a problem with the pad or possibly a warped platen if the machine has ever overheated severely. On the other hand if the transfer failed in the same area on the transfer (after changing the location of where the problem had previously been occurring), then you most likely have a problem with the transfer or it’s application settings (Temperature, Time or Pressure) and you should contact your transfer supplier to discuss the problem.

Following these basic guidelines can help you be more successful with each and every transfer!

INSTALLATION

3. Set pressure Turn Knob below air gauge right to increase pressure. Left to decrease pressure.

NOTE: air pressure will not decrease until machine cycles. Set starting pressure to 40-50 PSI.

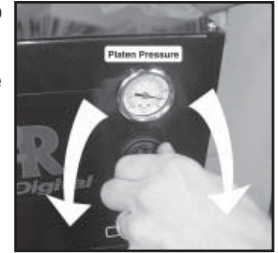

4. Push Emergency stop button.



5. Make sure auto/manual button is in the “out” manual position. (Press and release to change button position)



6. 2. Plug the machine into the correct grounded electrical outlet.

WARNING: When using an extension cord, use 12 or 14 ga.-3 conductor. Maximum length, 25’ (7.762 m).

ATTENTION: Utiliser des rallonges d’au moins 12 à 14 ga - 3 phases; longueur maximale de 7.7 mètres.

7. Now rotate Emergency stop button to the right (clockwise) to release.



INSTALLATION

8. Push Yellow power button. Time/Temp display will light.



9. Set your desired time and temp.
- To change or set the temperature, press the menu button on the digital control. The light next to "TEMP" will light. Press the up ▲, or down ▼, button to your desired setting.
 - To change or set the time, press the menu button on the digital control. The light next to "TIME" will light. Press the up ▲, or down ▼, button to your desired setting.
 - When you have your desired settings **press the menu button a third time to lock in your settings** otherwise the previous settings will still be used.
 - Wait for the machine to reach your preset temperature by monitoring the display temperature until it matches the set temperature.
 - Daily cycle is displayed by holding the up key while powering up. It will continue to display counts (up to 9999) while the up key is pressed. When the key is released it goes to regular mode.
10. Remove Reel Quick Knob and reel face flange (non motor side).

Reel Quick Knob



Reel Face Flange

Note: Quick Knobs can be slid off after rotating approximately one turn.

12. Load full reel on supply side (non motor side)
 13. Feed Label over top guide rod, under elbow rod and over the sensor.

Top Guide Rod



Elbow Rod

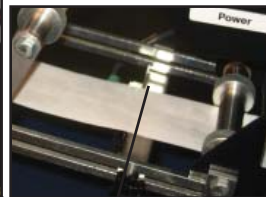

Sensor

SENSOR SETTING

9. Now adjust position of sensor head such that the light beam is just above the Index mark (approx. 3mm) and tighten.



NOTE: When sensing an index mark on a reflective (shiny) material, mount the sensor at approximately 15° off perpendicular to the material's surface to minimize strong direct reflections and allow the sensor to discern the relatively small optical contrast offered by differences in colors.

When sensing an index mark on a clear material, position a reflective surface directly behind the clear material to return light to the sensor. Most clear materials are also shiny; it is important to include a 15° skew angle when sensing clear materials.

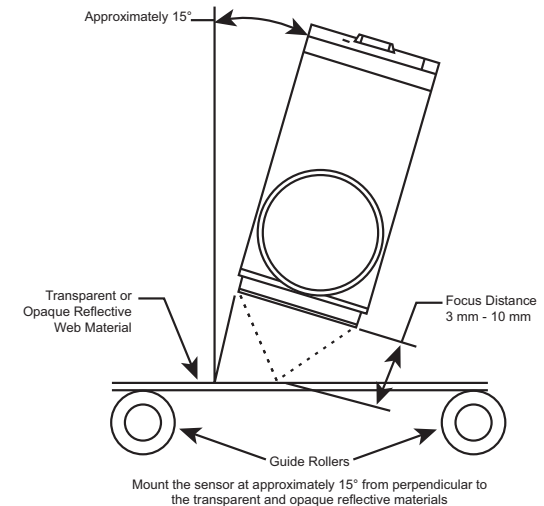

For further sensor instructions, see inclosed Banner R58E Series Expert™ Registration Mark Sensor manual

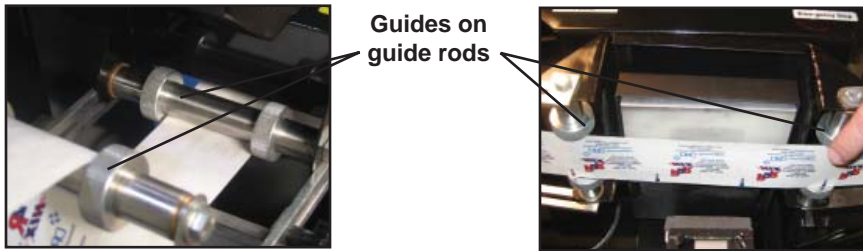

SENSOR SETTING

2. Reposition guides on guide rod to maintain front to rear centering of label. Do not adjust left to right position at this time.

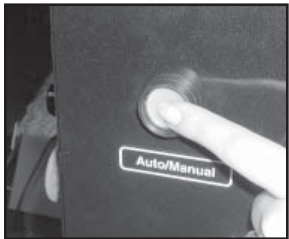

3. Depress manual/auto button to the "out" position or manual mode



4. Position sensor light on eye mark printed on label web.
5. Press and hold the Dynamic push button for >2 seconds. 
6. Continue to hold the Dynamic push button. Pass the index mark under the sensor (flashing light) at least twice.
7. Release the Dynamic push button. 
8. Put machine in Auto Mode (button in) and activate optical control switch, the label will advance to next index mark and stop. Position label front to rear if necessary (Step 2 of sensor setting) and right to left on lower platen, using jog button.

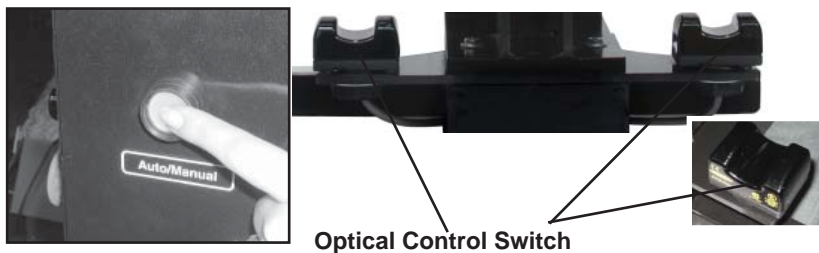

INSTALLATION

Continue web underneath heat platen and underneath right elbow web guide. Feed over top guide rod and through slot in drive roller mount.

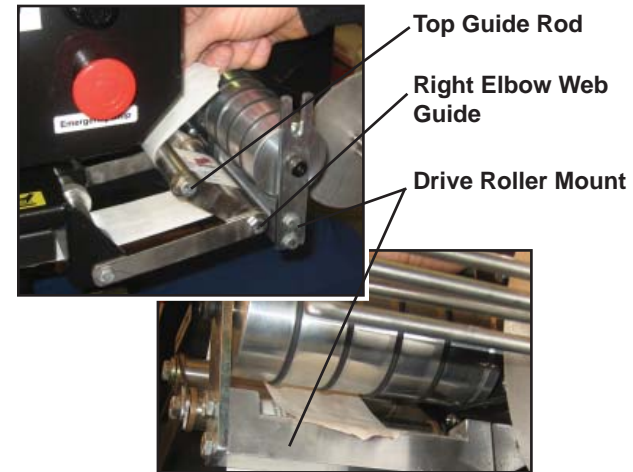

For effective web tracking labels should be fed between drive roller and pinch roller then back over top of pinch roller.

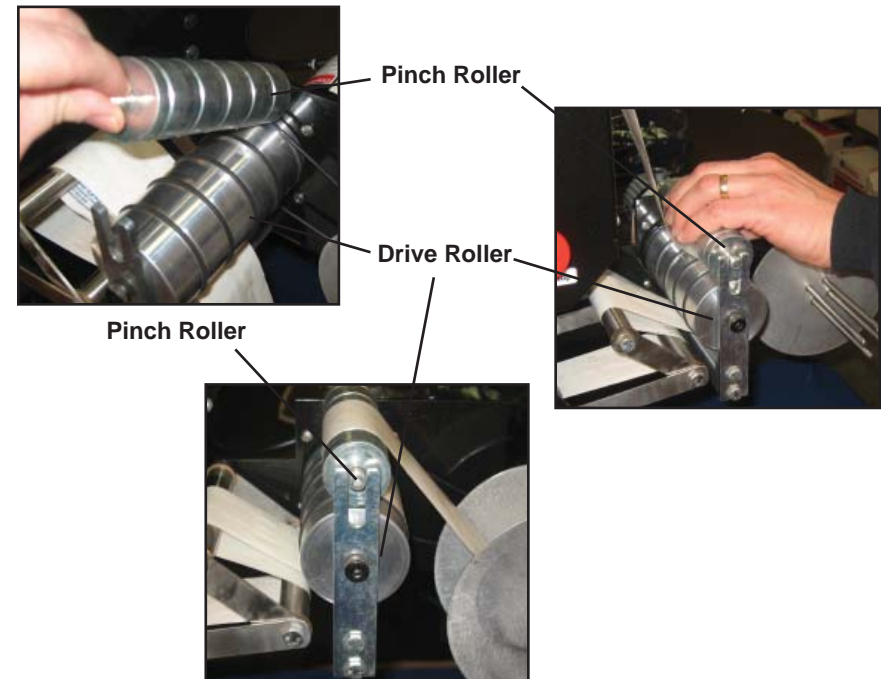

INSTALLATION

Simply place lead edge of label web between four fingers of take up reel and let hang free.

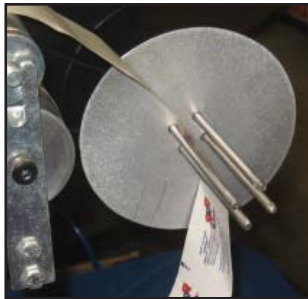

14. Take up slack by pressing and releasing Jog button on left side of control box.



15. Set sensor position and sensitivity. (See sensor section page 8)



Index Mark



16. Position label on platen then move sensor to align its light beam on the index mark.

17. Push manual/auto button to "In" position to set in auto mode.



OPERATION

1. Visually check and confirm label is in centered position.
(**Note:** If it is NOT repeat sensor setting Page 8)
2. Position Garment into desired position



3. Place finger in each optical control switch, heat head will come down and then rise after set time, take up roll will automatically index to next label. **Warning: Watch Hands!**



SENSOR SETTING

1. Jog label by depressing and releasing the Jog button to move the label index mark such that the light beam is aimed on the Index mark. (or hand move)



Index Mark

